



## User's Guide

### Model 3554 Lift-Off™ Upright Vacuum & Detachable Canister

- Assembly
- Operation
- Maintenance
- Troubleshooting

*Thanks for buying a BISSELL Lift-Off™ Upright Vacuum.*

We're glad you purchased a BISSELL Lift-Off Upright Vacuum & Detachable Canister. Everything we know about floor care went into the design and construction of this powerful, innovative home vacuuming system.

Your BISSELL Lift-Off is well made, and we back it with a comprehensive one-year warranty. We also stand behind it with a knowledgeable, dedicated Consumer Service department, so, should you ever have a problem, you'll receive fast, considerate assistance.

My great-grandfather invented the floor sweeper in 1876. Today, BISSELL is a global leader in the design, manufacture, and service of high quality homecare products like your BISSELL Lift-Off.

Thanks again, from all of us at BISSELL.

Mark J. Bissell  
President and Chief Executive Officer

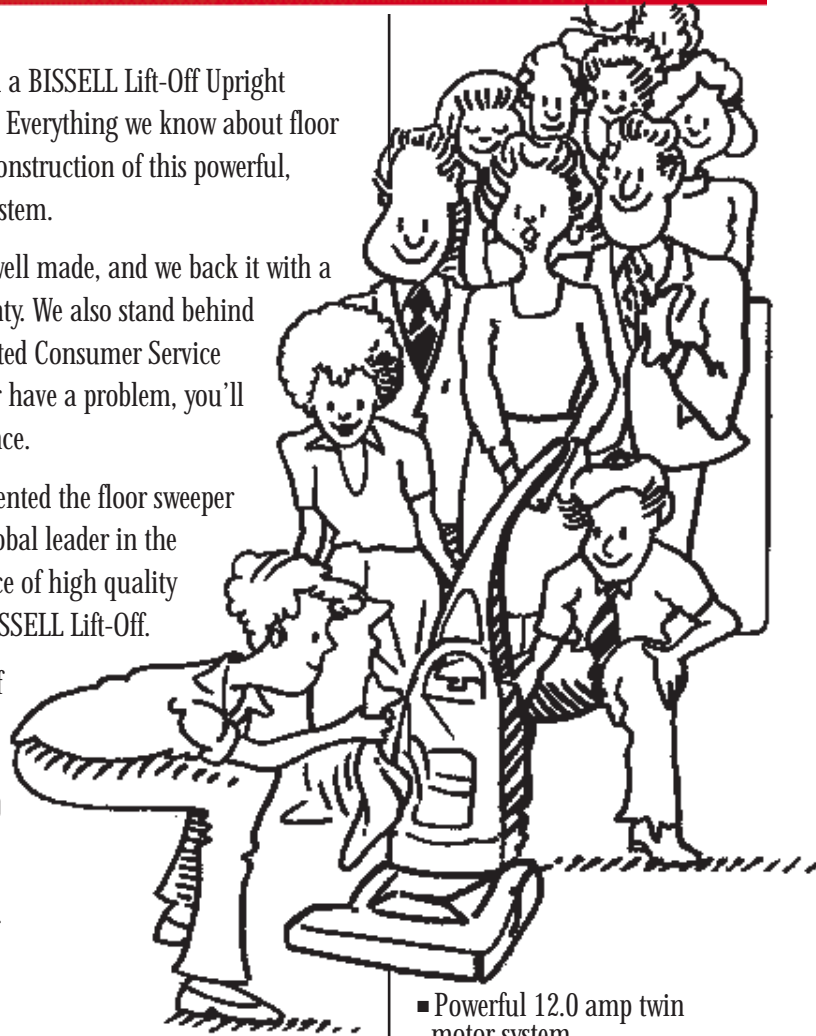

- Powerful 12.0 amp twin motor system
- Detachable canister
- Filtrete™ Vacuum Filter System from 3M
- Wide 14" cleaning path
- Self-adjusts to all floor surfaces
- 5 specialized tools for all vacuuming needs

# IMPORTANT SAFETY INSTRUCTIONS

**When using an electrical appliance, basic precautions should be observed, including the following:**

Read all instructions before using your upright. Always connect to a polarized outlet (left slot is larger than right). Unplug from outlet when not in use and before conducting maintenance.

**WARNING:** To reduce the risk of fire, electric shock, or injury, do not use outdoors or on wet surfaces.

- Do not modify the polarized plug to fit a non-polarized outlet or extension cord
- Do not leave vacuum cleaner when it is plugged in
- Do not perform maintenance when vacuum cleaner is plugged in
- Do not use with damaged cord or plug
- Do not unplug by pulling on cord. To unplug, grasp the plug, not the cord
- Do not pull or carry by cord, use cord as a handle, close door on cord, pull cord around sharp corners, run vacuum cleaner over cord, or expose cord to heated surfaces
- If appliance is not working as it should, has been dropped, damaged, left outdoors or dropped into water, return it to a Service Center.
- Do not allow children to operate vacuum cleaner or use as a toy
- Do not handle vacuum cleaner or plug with wet hands
- Do not carry the vacuum cleaner while it is running
- Do not put any object into ventilation openings, use with blocked opening, or restrict air flow
- Do not use without Vacuum Bag and/or filters in place
- Do not expose hair, loose clothing, fingers or body parts to openings or rotating floor brush
- Do not pick up hot coals, cigarette butts, matches or any hot or burning objects
- Do not pick up hard or sharp objects such as glass, nails, screws, coins, etc.

- Do not pick up flammable or combustible materials (lighter fluid, gasoline, kerosene, etc.) or use in the presence of explosive liquids or vapor
- Do not pickup toxic material (chlorine bleach, ammonia, drain cleaner, gasoline, etc.)
- Do not use vacuum cleaner in an enclosed space filled with vapors given off by oil base paint, paint thinner, some moth proofing substances, flammable dust, or other explosive or toxic vapors
- Do not use for any purpose other than described in this User's Guide
- Use only manufacturer's recommended attachments
- Use only on dry, indoor surfaces
- Keep openings free of dust, lint, hair, etc.
- Keep appliance on a level surface
- Turn off all controls before plugging or unplugging vacuum cleaner
- Be extra careful when cleaning stairs
- Pay close attention when working around children

**SAVE THESE INSTRUCTIONS FOR FUTURE USE.**

**THIS APPLIANCE HAS A POLARIZED PLUG.**

To reduce the risk of electric shock, this appliance has a polarized plug (one blade is larger than the other). This plug will fit in a polarized outlet only one way. If the plug does not fit fully in the outlet, reverse the plug. If it still does not fit, contact a qualified electrician to install a proper outlet. Do not change the plug in any way.

This model is for household use only.

**⚠ WARNING:** Do not plug in your vacuum cleaner until you have completely assembled it per the following instructions and are familiar with all instructions and operating procedures.

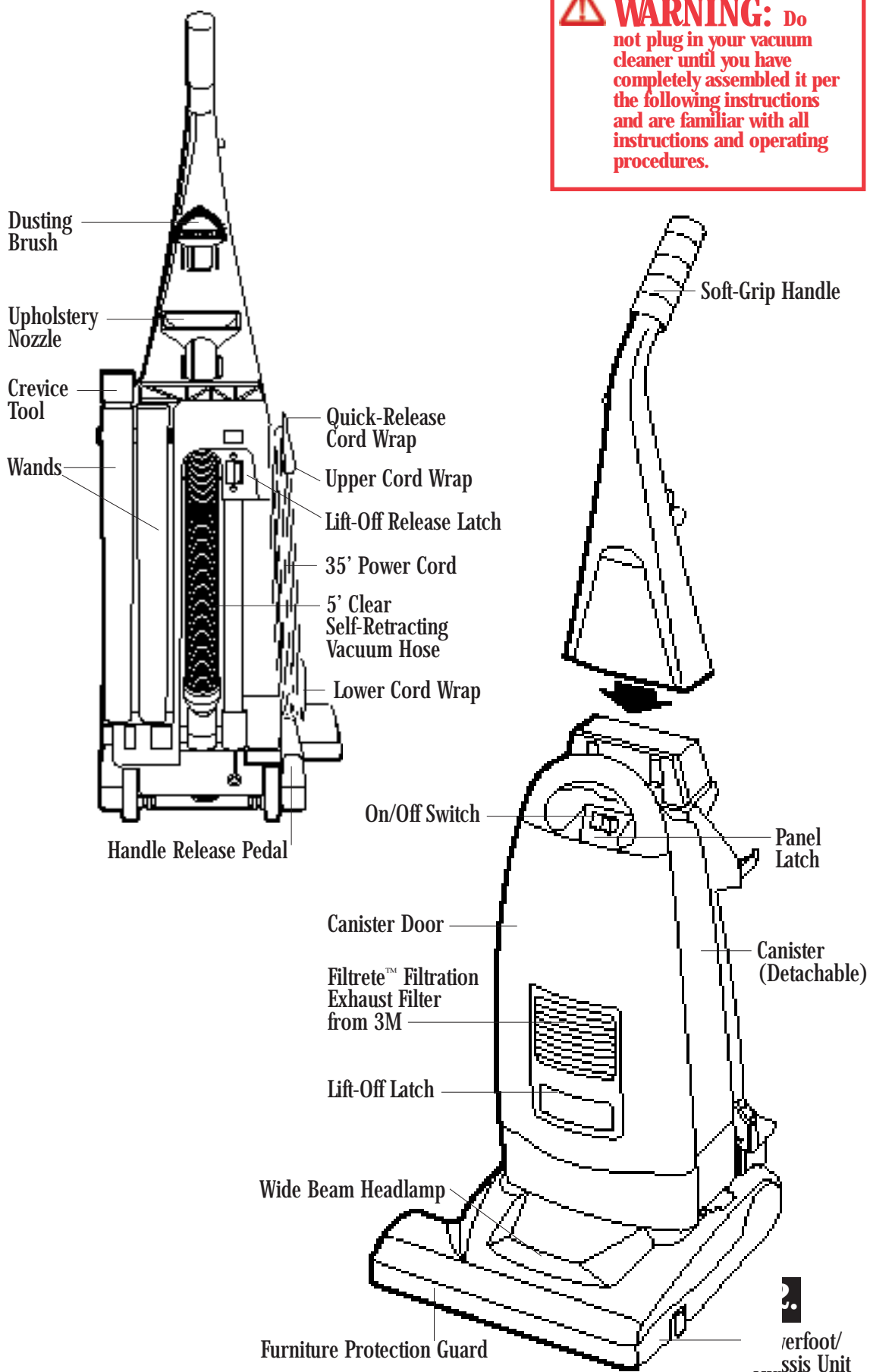

## How to use this guide

This User's Guide has been designed to help you get the most satisfaction from your BISSELL Lift-Off Upright Vacuum & Detachable Canister. You'll find assembly and operating instructions, safety precautions, as well as maintenance and troubleshooting instructions. Please read this Guide thoroughly before assembling your vacuum cleaner.

Pay particular attention to the assembly diagram, assembly instructions, and part names. Locate and organize all parts before assembly. Familiarize yourself with the parts and where they go. Following this User's Guide will greatly enhance your ability to get the most performance from your BISSELL Lift-Off for many years.

### How to put it together

No tools are required to assemble your BISSELL Lift-Off.



#### **WARNING:**

**Plastic bags or plastic film can be dangerous. To avoid danger of suffocation, keep away from babies and children.**

### Attach Vacuum Body to Powerfoot

- 1.** Remove protective plastic film from Powerfoot and Handle and dispose.
- 2.** Place Powerfoot on floor with rotating floor brush on floor surface.
- 3.** Place Handle on Chassis as shown and push down firmly. You will hear a 'click' when the three tabs on the Handle lock into matching openings on the Chassis.

**Assembly is now complete.**

# Index

Safety instructions	2
Product view	3
How to put it together	4
Special tools	5
Index	5
How to use your BISSELL Lift-Off	6
Cleaning carpet, rugs or bare floors	7
Routine maintenance	8-11
Troubleshooting	12
Replacement parts	13
Warranty	14
Consumer Service	14

## Special tools for every job

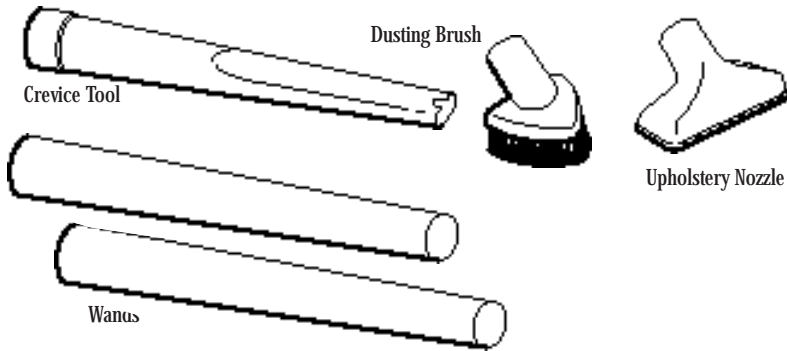

Your BISSELL Lift-Off is not only a powerful carpet and rug vacuum cleaner, it's also a versatile above floor vacuum cleaner when you select one of the five special tools included. Tools may be used with the Detachable Canister on or off the Powerfoot/Chassis.

- **Dusting Brush** - For dusting surfaces such as table tops, mantles, lamp shades, drapes, woodwork, etc.
- **Wands** - For extra length or reach.
- **Crevice Tool** - For tight, narrow spaces.
- **Upholstery Nozzle** - For small area vacuuming such as upholstered household furniture, automobile interiors, drapery, etc.

**Tip:**  
Hair, string and small objects can block the Vacuum Hose or Tools. Check them occasionally for obstructions. See Troubleshooting Guide for instructions.

## How to use your BISSELL Lift-Off

### Power Cord Quick Release

The Power Cord is stored at the side of the Detachable Canister, wrapped around two Cord Wraps. A molded clip on the polarized plug allows it to be fastened to the Power Cord during storage.

1. Unclip polarized plug from Power Cord.
2. Rotate the Upper Cord Hook one-half turn right or left, and slip Power Cord from Upper and Lower Cord Wraps.
3. Plug in the Power Cord Plug into a polarized outlet.
4. To keep the Power Cord out of your way while cleaning, place it in the Cord Hook, located near the top of the Handle.

### Power Switch

The Power Switch is located just below the carry handle on the Detachable Canister. Push the rocker switch "ON" to vacuum, and "OFF" when cleaning is complete.

**NOTE:** This unit is equipped with a special internal switch that turns the rotating brush off whenever the unit is in the upright position.

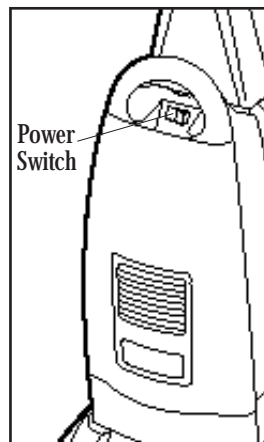
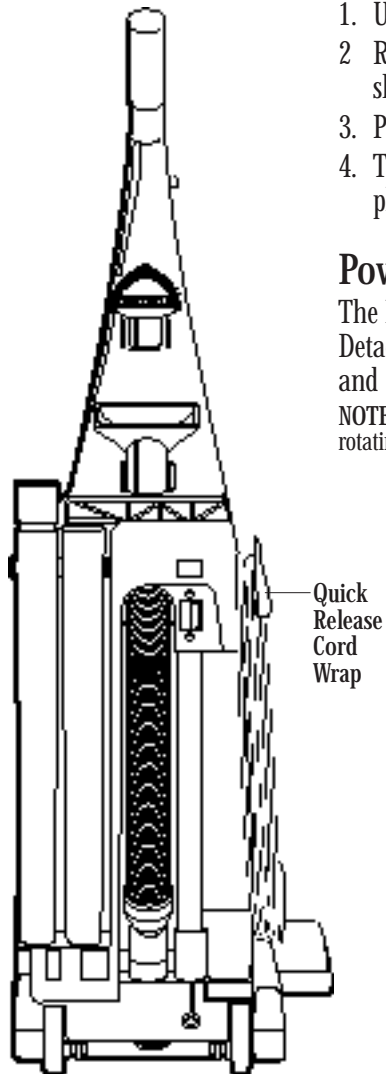

# Cleaning carpet, rugs or bare floors

## Handle Release Pedal

Press the Handle Release Pedal with your foot to change your Lift-Off from full upright/above floor cleaning position to normal carpet cleaning position, or for low cleaning under beds and low furniture. Always store or transport in the full upright position, rolling the cleaner on rear wheels only.

## Cleaning with the Detachable Canister

The Detachable Canister feature makes it possible to take the powerful cleaning action of your BISSELL Lift-Off to stairways, auto interiors, or other hard-to-reach areas of your home.

Before detaching the Canister, your Lift-Off must be in its fully upright position. You do not need to turn off the power first.

1. Press the Lift-Off Release Latch at the back of the Chassis and lift the Canister to remove.
2. Detach the Vacuum Hose from the port at the back of the PowerFoot.
3. Press fit the desired tool to the end of the Vacuum Hose.
4. When you're done, return the Canister to the Powerfoot/Chassis by sliding it straight down the Chassis over the power port and remove the tool used. The Lift-Off Latch will lock the Canister in place. Reconnect the Hose to the vacuum port.

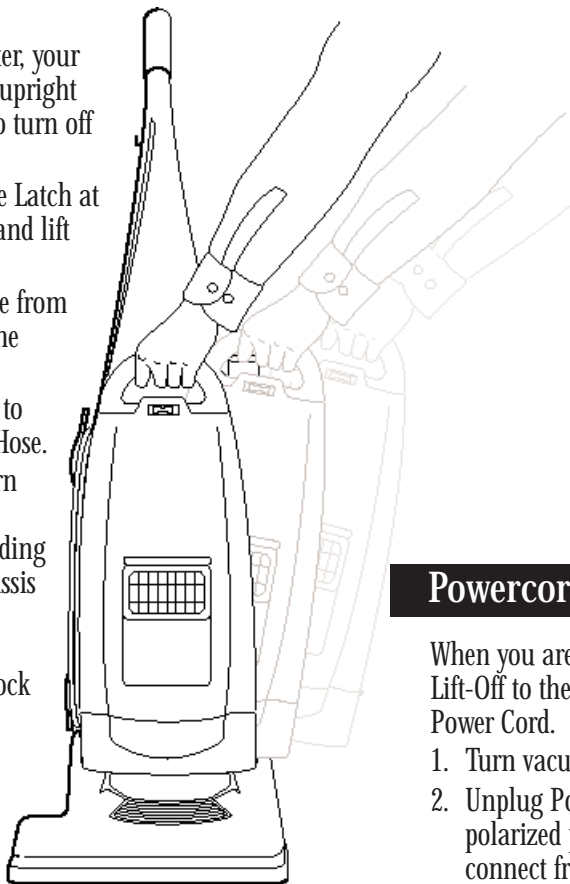

**CAUTION:** Always place vacuum cleaner on floor in its fully upright position, and make sure it is locked into place before removing Canister or when using tools. Placing the Lift-Off in its full upright position automatically stops the rotating brush, and the headlight will turn off.

## Tip:

Before cleaning under low furniture, check for objects that might harm the rotating floor brush or block the vacuum hose. Do not pick up hard or sharp objects such as glass, nails, screws, coins, paper clips, etc.

## Powercord Storage

When you are done cleaning, return your Lift-Off to the Upright position and store the Power Cord.

1. Turn vacuum cleaner OFF.
2. Unplug Power Cord by grasping the polarized plug (NOT the cord) and disconnect from outlet.
3. Loop Power Cord around Cord Wraps on the side of Canister.
4. Clip molded plug to Power Cord to secure.

## Routine maintenance

To maintain maximum performance from your BISSELL cleaner, perform these simple maintenance checks periodically.



**WARNING:** To reduce the risk of injury from moving parts, and/or electrical shock, turn Power Switch OFF and disconnect polarized plug from electrical outlet before servicing.

For average household use, follow this maintenance schedule:

- |                 |   |
|-----------------|---|
| Every Week:     | Check the Filtrete Vacuum Filter Bag (page 8) and Filtrete Exhaust Filter (page 10) |
| Every Month:    | Check the Drive Belt and Rotating Brush (page 9)                                    |
| Every 6 Months: | Replace the Filtrete Exhaust Filter (page 10)                                       |

### Replace Vacuum Bag

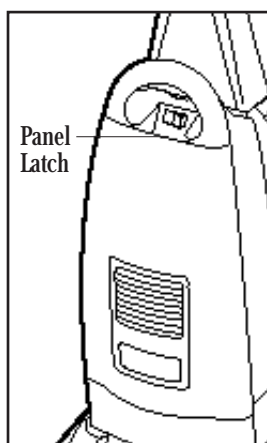

#### Tip:

Vacuuming new carpet or fine powders such as drywall dust can rapidly fill the Vacuum Bag, so check it more frequently.

To maintain peak vacuum efficiency, you should check the Filtrete Vacuum Filter Bag weekly, and replace it when it is no more than three-quarters full.

#### Never reuse a Vacuum Bag.

1. Remove front canister panel by pressing Panel Latch, as shown. Pull panel forward to remove.
2. If bag is three-quarters full (or more), place your fingers behind the collar and gently slide it from the dirt tube. Discard the Vacuum Bag.
3. Press the Handle Release Pedal and lower cleaner to fully reclined position (laying the handle on the floor).
4. Fold top of new bag forward and grasp both sides of the cardboard collar with your hand. Put your fingers through the hole in the collar to create an opening for the dirt tube.
5. Match the bag with the tabs at the back of the Canister, and angle to place the collar under the tabs.
6. Gently push the bag onto the dirt tube until the entire collar touches the back of the Canister.
7. Position canister panel so bottom tabs fit into slots. Push panel closed until it snaps into place.

### Replacement Bags

Use only BISSELL Style 4 bag made with Filtrete™ technology from 3M (#32031, package of 2) in your BISSELL Upright Vacuum Cleaner.

You may purchase the Bag at your local retailer, with the order form in this User's Guide, or by calling

#### **BISSELL Consumer Services**

**1-800-237-7691**

Monday - Friday 8 a.m. – 7 p.m. EST

Saturday 9 a.m. – 2 p.m. EST

or from the BISSELL website –

<http://www.bissell.com>



## Check Rotating Floor Brush and Drive Belt

Check the Drive Belt and Rotating Floor Brush regularly for wear or damage. You should also remove string, hair, and carpet fibers from the Brush and Brush ends. These can wrap around the brush and hamper its ability to effectively clean your carpet.

1. Unplug the unit, then press Handle Release Pedal to position cleaner in full recline position.
2. Turn entire cleaner over to expose bottom of Powerfoot.
3. Using a Phillips head  screwdriver, loosen the two screws that secure the Brush Cover.
4. Remove the Brush Cover and check the Belt for damage or wear, and the Brush for debris.
5. Check Belt carefully for wear, cuts or stressed areas. Inspect entire Belt by rolling Floor Brush with the palm of your hand several times in the direction of the motor pulley.
6. Check Air Passageway for obstructions. Remove debris from this area.

## Replace Drive Belt

1. Grasp the Brush at both ends and lift up.
2. Slide old Belt to clear motor pulley, remove Belt, and discard.
3. Loop new Belt over motor shaft and stretch other end over crown of Floor Brush.
4. Place Belt end of Brush into its slot and hold it in place with your hand, while slowly pulling opposite end of Brush down into its slot with your right hand.
5. Turn Brush by hand several times in direction of pulley. If properly installed, the Belt will center itself on brush crown.
6. Replace Brush Cover. Be sure to align and insert front edge of Brush Cover and secure with screws.

## Replacement Belts

Use only BISSELL Replacement Belt (#32035, package of 2) in your BISSELL Upright Vacuum Cleaner. You may purchase these Belts:

at your local retailer.

with the order form in this User's Guide.

or by calling

**BISSELL Consumer Services**

**1-800-237-7691**

Monday - Friday 8 a.m. – 7 p.m. EST

Saturday 9 a.m. – 2 p.m. EST

or from the BISSELL website –

<http://www.bissell.com>

## Check/Replace Filtrete™ Exhaust Filter

To keep your Lift-Off operating at peak efficiency and to remove irritating allergens from your home, you should change the Filtrete Exhaust Filter from 3M every six months. The self-contained filter easily pulls outward from the top, and the new one snaps into place.

### Replacement Filter

Use only BISSELL Style 4 Filtrete Exhaust Filter (#32032, package of 1) in your BISSELL Upright Vacuum Cleaner.

You may purchase the filter:

at your local retailer,

with the order form in this User's Guide,

or by calling

**BISSELL Consumer Services**

**1-800-237-7691**

Monday - Friday 8 a.m. – 7 p.m. EST

Saturday 9 a.m. – 2 p.m. EST

or from the BISSELL website –

<http://www.bissell.com>

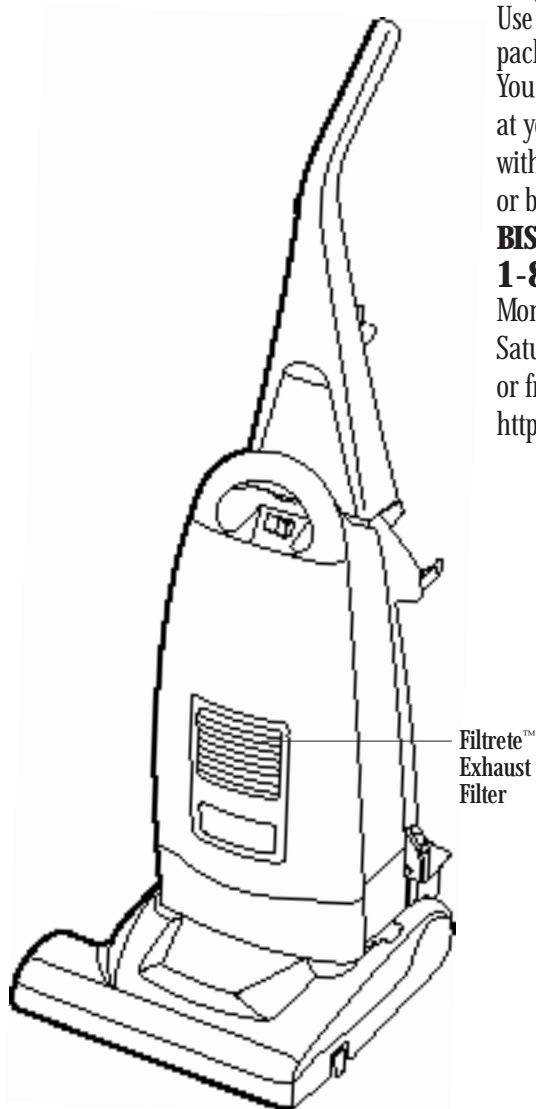

## Replace Lightbulb

You may need to replace the Lightbulb in your Lift-Off. Remember, the light isn't on unless the brush is rotating. It is off when the cleaner is upright, and/or when the Canister is removed for use with cleaning tools.

1. Remove the clear plastic lens at the front of the Powerfoot by gently inserting a small, flat-blade  screwdriver into the notch at the bottom of the lens.
2. Remove the old bulb by pulling it straight out of socket- do not twist. Gently push replacement bulb into socket.
3. Reposition lens over opening and snap into place.

### Replacement Bulbs

Use only BISSELL Replacement Bulbs (#0101178) in your cleaner. You may purchase these Bulbs with the order form in this User's Guide.

or by calling

**BISSELL Consumer Services**

**1-800-237-7691**

Monday - Friday 8 a.m. – 7 p.m. EST

Saturday 9 a.m. – 2 p.m. EST

or from the BISSELL website –

<http://www.bissell.com>

# Troubleshooting



**WARNING:** To reduce the risk of injury from moving parts and/ or electrical shock, turn Power Switch OFF and disconnect polarized plug from electrical outlet before performing troubleshooting checks.

## ***Vacuum cleaner won't run***

Possible Causes	Remedies
Vacuum cleaner is not plugged in	Check electrical plug
Household fuse/breaker	Check/replace fuse - Reset breaker button. Call BISSELL Consumer Services

## ***Vacuum cleaner won't pick up dirt***

Possible Causes	Remedies
Vacuum Bag is full	Replace with new bag
Vacuum Hose is clogged at Powerfoot	Remove canister. Recline cleaner. Check Hose/hose port for debris and remove if necessary
Rotating Brush Drive Belt broken	Replace Drive Belt
Drive Belt stretched/off Motor Pulley Shaft	Reposition Belt/clean Brush/Belt areas or replace worn Belt
Rotating Floor Brush bristles worn	Replace Brush
Rotating Floor Brush jammed	Remove Brush and clean debris from Brush ends
Height adjustment too high	Reset Floor Surface Selector setting

## ***Tools won't pick up dirt***

Possible Causes	Remedies
Vacuum Hose, Wands or Tools clogged	Visually check for objects blocking suction path and remove carefully

## ***No power at rotating floor brush***

Possible Causes	Remedies
Canister is not securely seated	Press Lift-Off Latch, remove canister and replace it properly
Rotating Brush Drive Belt Broken	Replace Drive Belt
Drive Belt stretched/off Motor Pulley Shaft	Reposition Belt/clean Brush/Belt areas

# Replacement part numbers and descriptions

Item	Part No.	Part Descriptions
1	32031	Filtrete™ Vacuum Bag from 3M (package of 2)
2	32032	Filtrete™ Exhaust Filter from 3M (package of 1)
3	32035	Drive Belt (package of 2)
4	0101178	Headlight Bulb
5	0109664	Wand
6	0109157	Crevice Tool
7	0109179	Upholstery Nozzle
8	0101162	Dust Brush

If suggested solutions for this or any function of your Upright Vacuum Cleaner do not correct the problem, call

**BISSELL Consumer Services**

**1-800-237-7691**

Monday - Friday 8 a.m. – 7 p.m. EST

Saturday 9 a.m. – 2 p.m. EST

or from the BISSELL website –

<http://www.bissell.com>

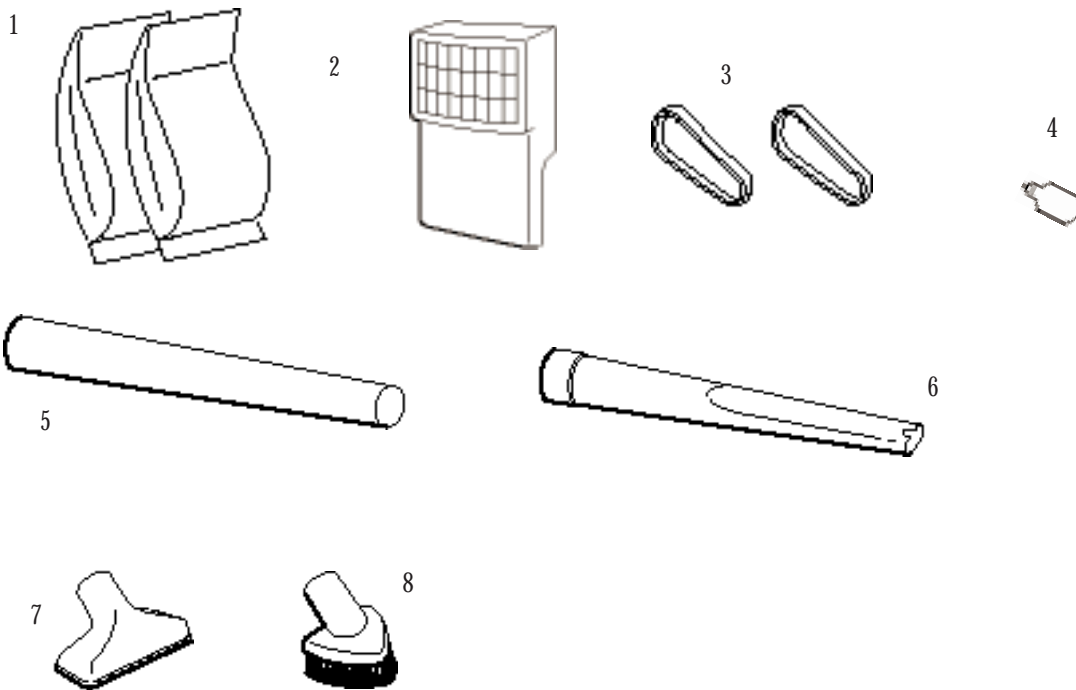

## About your warranty

This warranty gives you specific legal rights, and you may also have other rights which may vary from state to state. If you need additional instruction regarding this warranty or have questions regarding what it may cover, call BISSELL Consumer Services.

### One Year Warranty

BISSELL Inc., upon receipt of the product, will repair or replace, free of charge, any part which is defective or malfunctioning within one year of the purchase date, provided that it is used for personal and not commercial or rental service. If the vacuum cannot be repaired, BISSELL Inc. will replace or refund the full price, at your option.

### If your BISSELL product should require service:

1. Call **BISSELL Consumer Services at 1-800-237-7691** and we will give you the name and address of an authorized **BISSELL Service Center** in your area. Or visit the **BISSELL website - <http://www.bissell.com>**
2. If there is not an authorized **BISSELL Service Center** in your area, a **BISSELL Consumer Services Representative** will issue you a **Return Authorization Number** and a **pre-paid mailing label** to return the unit to **BISSELL**.
  - The product should be returned with a photocopy of your proof of purchase. (Your dated sales receipt is your warranty - **do not send original.**)
  - Insure the machine when shipping for your protection from loss.

## BISSELL Consumer Services

For information about repairs or replacement parts, or questions about your warranty, call:

**BISSELL Consumer Services**

**1-800-237-7691**

Monday - Friday 8 a.m. — 7 p.m. EST

Saturday 9 a.m. — 2 p.m. EST

Or write:

**BISSELL INC**

**PO Box 3606**

**Grand Rapids MI 49501**

**ATTN: Consumer Services**

When contacting BISSELL, have model number of unit available.

Please record your Model Number: \_\_\_\_\_

Please record your Purchase Date: \_\_\_\_\_

**NOTE: Please keep your original sales receipt. It is your warranty.**

**It is suggested you staple your original sales receipt to the front of this guide.**



Life's messy. Clean it up.®

©1998 BISSELL Inc  
Grand Rapids, Michigan  
All rights reserved. Printed in USA  
Part Number 010-5739

Visit our web site at:  
<http://www.bissell.com>